

Assembly Instruction

Family Bed CAPRI

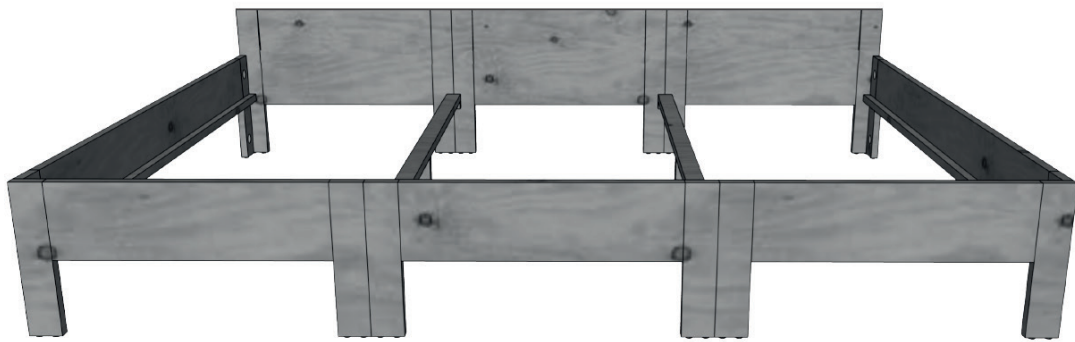

ORIGINAL RIMA

Familienbett

Dear family bed sleepers,

by selecting a product from RIMA GmbH, you have made an excellent decision. It is important that you carefully read and follow the assembly instructions provided to ensure proper use of the product.



WOOD - A NATURAL PRODUCT

Wood is a natural material that is affected by the humidity of the surrounding air. With careful maintenance, you will enjoy your family bed for many years.



CHECKING THE LIST OF PARTS

Before you start assembling, please check the completeness of the components according to the parts list.



FINALLY

Please be aware that we may make technical modifications. We now wish you lots of fun and success assembling your bed and many peaceful nights in your family bed.



GENERAL INFORMATION:

Assembly time approx. 60 minutes (2 people)

Use the four wooden slats as spacers between the slatted frames. These prevent the slatted frames from slipping.

The holes in the middle headboard and footboard are unnecessary when setting up the family bed. These are used later for conversion to a single bed if required.

SOMETHING DOESN'T WORK?



Mistakes happen!

Although we try very hard, it can happen that something doesn't work out. If items, packages or components are missing or damaged in your delivery, please let us know the item or package number so we can quickly allocate them and send you a replacement without delay.



office@familienbett.at



+43(0) 3612 / 250 25



CHECKING THE LIST OF PARTS





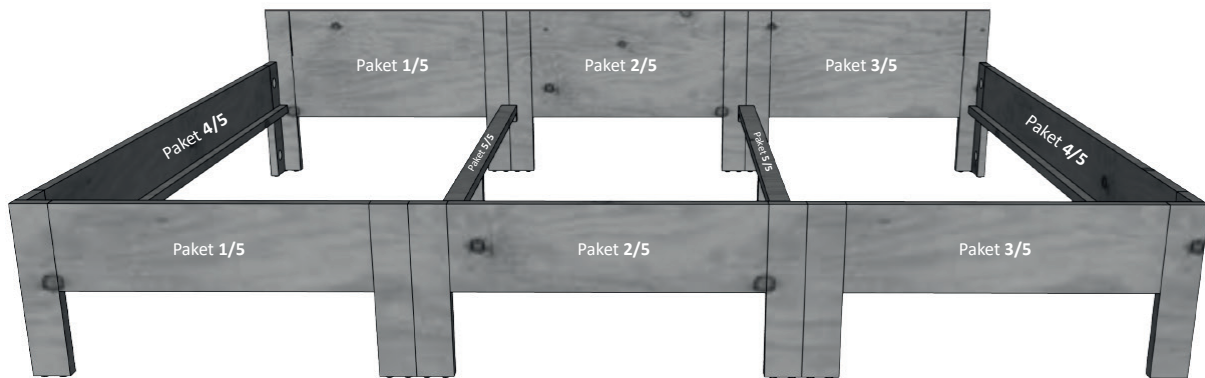

The following wooden elements are included:

- (DE) Paket **1/5** - linkes Kopf- und Fußteil
(EN) Package **1/5** - left headboard and footboard
- (DE) Paket **2/5** - mittleres Kopf- und Fußteil
(EN) Package **2/5** - middle headboard and footboard
- (DE) Paket **3/5** - rechtes Kopf- und Fußteil
(EN) Package **3/5** - right headboard and footboard
- (DE) Paket **4/5** - Seitenteile
(EN) Package **4/5** - bedrails
- (DE) Paket **5/5** - Lattenrostauflagen + Beschläge
(EN) Package **5/5** - slatted base supports + fittings



CHECKING THE LIST OF PARTS

The following fittings are included:

- | | | | |
|---|--|---|--|
|  | 16 - Single bolts |  | 14 - Threaded screws |
|  | 16 - Eccentric housings |  | 12 - Wooden dowels |
|  | 6 - Cover Caps
<i>*for the back of the headboards</i> |  | 4 - Spacers (wooden strips)
<i>*Information on page 2</i> |
| | |  | 1 - Allen wrench for eccentric |

1 START BY CONNECTING THE HEADBOARDS

Note: The holes are on the back of the headboards and inside the family bed for the footboards and bedrails.

● Three holes on the left side at the middle headboard -> conversion to a single bed

Screw the 4 single bolts into the threaded bushes.

Insert the 4 eccentric housings into the holes. The arrow on the eccentric housing must be aligned with the hole so the single bolts can grip. *For the middle headboard on the left side, no eccentric housings are used. (Conversion to a single bed)

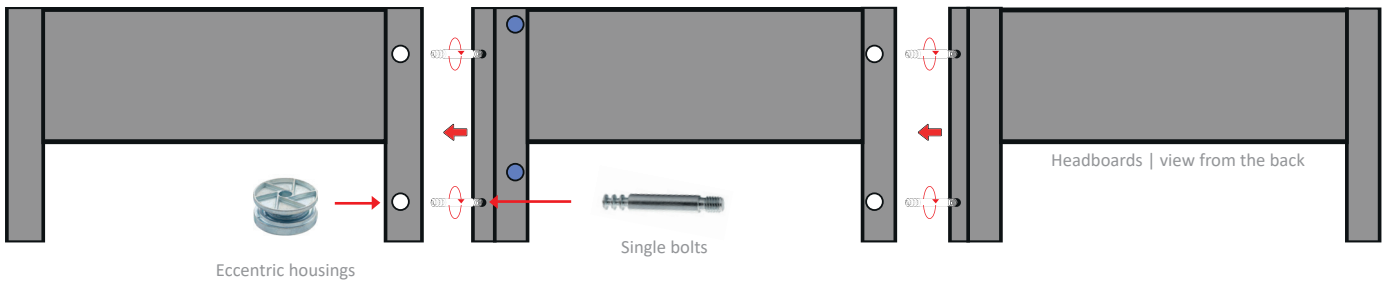

Next, proceed to connect the headboards. Use the spanner to tighten the eccentric housings evenly. Apply a little more force until the single bolts grip securely.

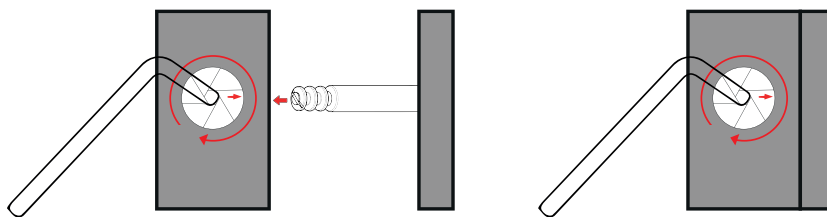

2 CONNECTING THE FOOTBOARDS

● 2 holes on the left side of the middle footboard -> conversion to a single bed

Insert the 4 eccentric housings into the holes.

The arrow on the eccentric housing must be aligned with the hole so the single bolts can grip.

*For the middle footboard on the left-hand side no eccentric housings are inserted in. (Single bed conversion)

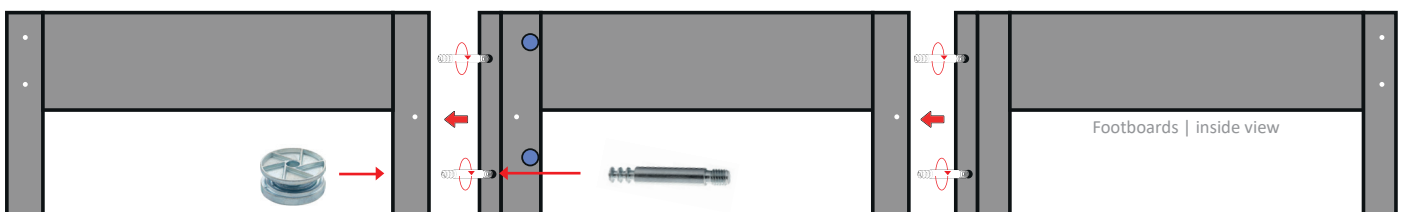

Next, attach the footboards using a spanner to evenly tighten the eccentric housings.

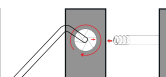

3

MOUNT THE BEDRAILS TO THE HEAD- AND FOOTBOARDS

Screw the 8 single bolts into the threaded bushes.
- 2x for the left headboard / 2x for the right headboard
- 2x for the left footboard / 2x for the right footboard

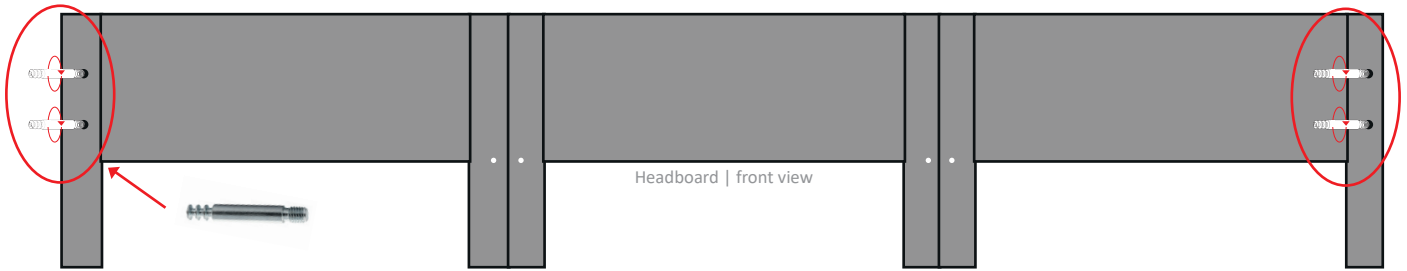

To assemble, insert the 8 eccentric housings into the holes located on the sideboards. Ensure that the arrow on the eccentric housing is aligned with the hole, allowing the single bolts to grip securely.

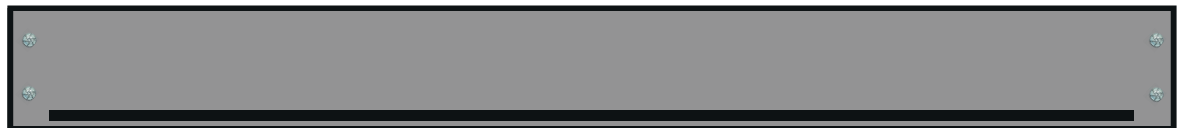

Then connect the head- and footboards to the bedrails. Use the spanner to tighten the eccentric housings evenly. A little more force is needed here until the single bolts grip.

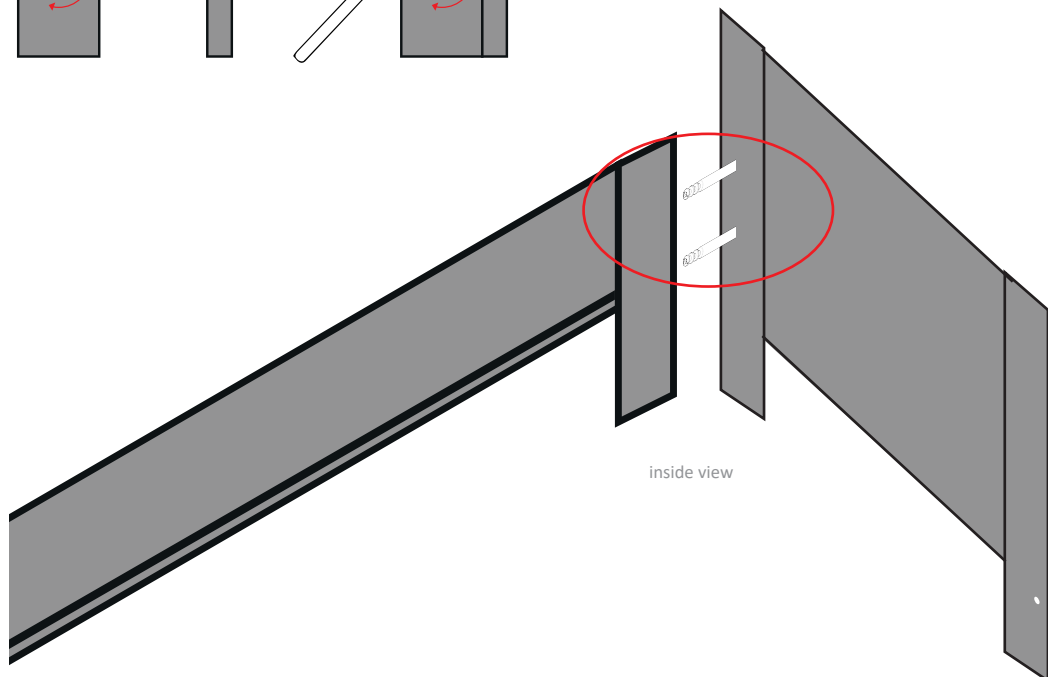
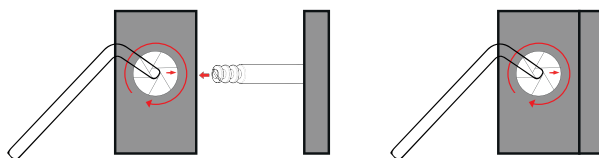

4

NOW THE SUPPORTS FOR THE SLATTED FRAMES ARE MOUNTED ON THE FAMILY BED.

Attach the four wooden blocks to the family bed with 2 threaded screws each.
- 2 pieces for the headboards and 2 pieces for the footboards.

4x

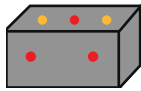

- Holes for the wooden dowels
- Holes for the threaded screws

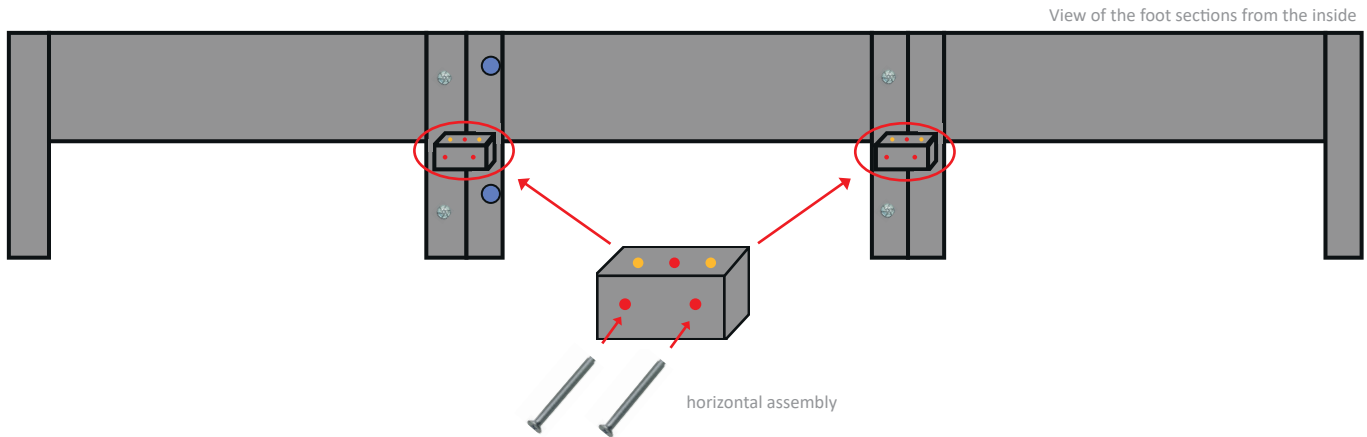

Then insert 2 wooden dowels into the two outer pre-drilled holes on the top of each wooden block.

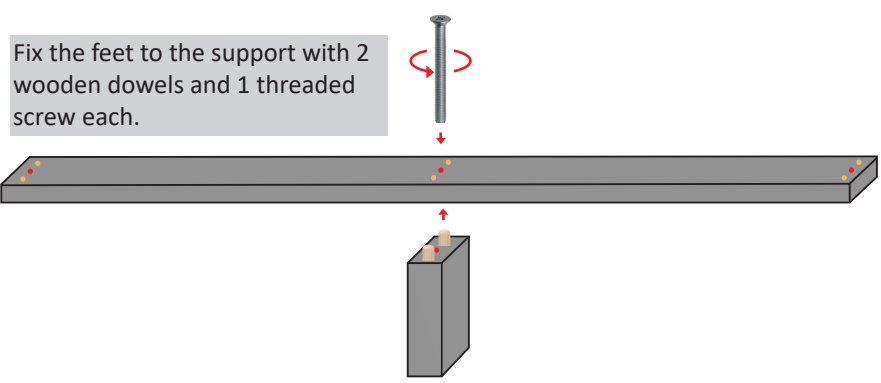
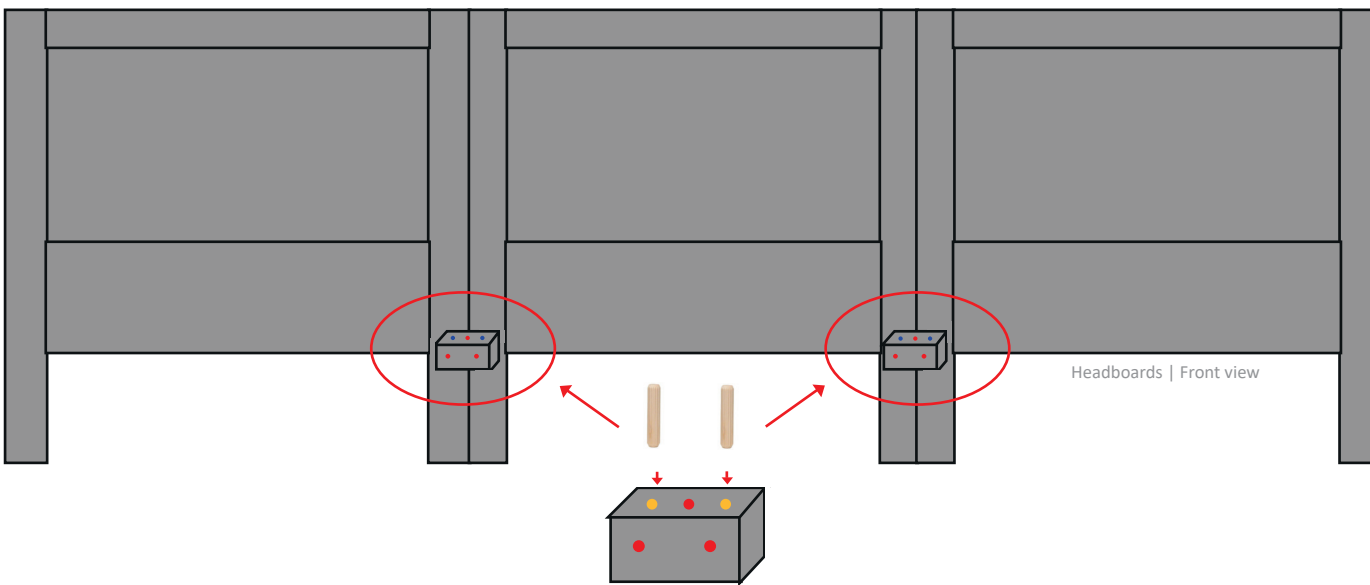

Place the slatted frame supports on the wooden blocks to assemble the bed and secure them with two threaded screws each.

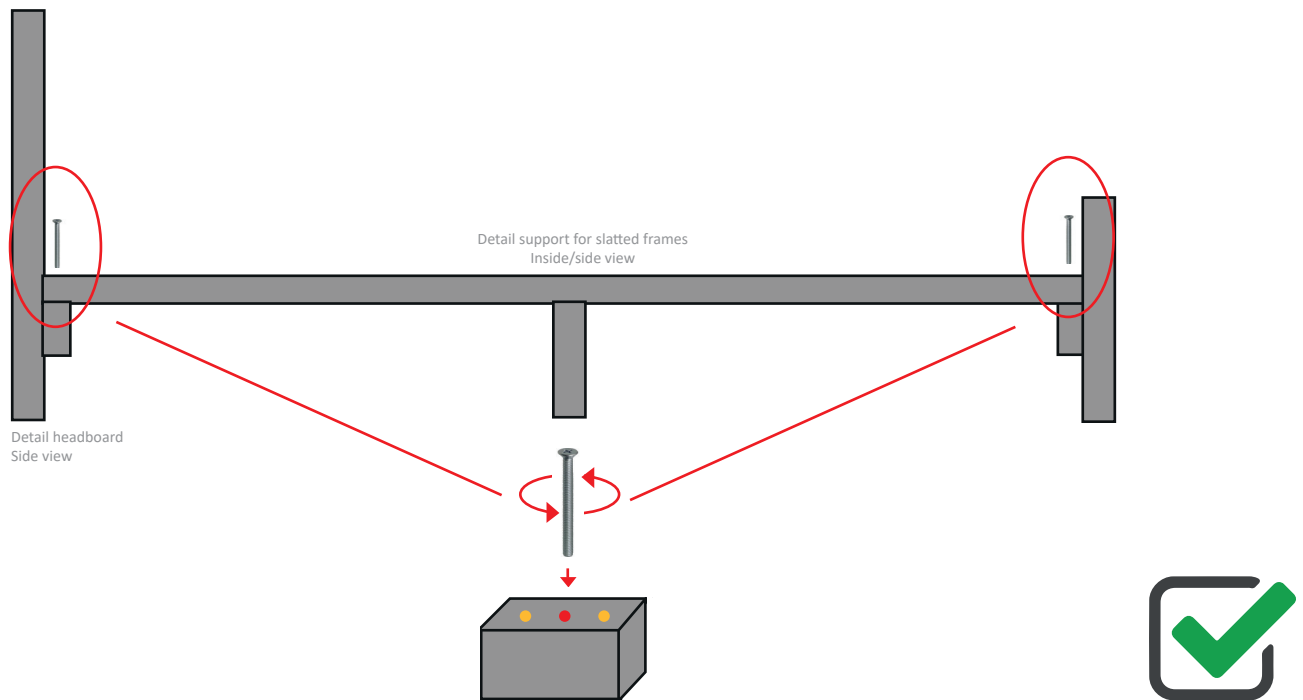

YOU DID IT!

Congratulations on setting up your RIMA family bed! Now you can enjoy peaceful nights with your loved ones.

FLEXIBLE MODULAR CONSTRUCTION

Conversion to a double bed:

Remove the middle headboard, footboard, and slatted base if you want to turn your family bed into a double bed. All you need is the Allen key from the assembly set and a small screwdriver (if needed). No extra wooden parts or fittings are necessary for this conversion.

Conversion to a single bed:

To create a single bed from your family bed, you will require the middle headboard and footboard and a „conversion set to single bed“ available on our online shop under Family beds/Conversion set. The conversion set has 2 side panels, 4 add-on slats, and fittings.

Extend the family bed by 90cm:

You can make your family bed bigger by extending it. With a quick attachment, you can create more space for your family.

PLEASE NOTE

Our family business is constantly evolving and responding promptly to our customers' needs. We value our customers' feedback and have incorporated many suggestions to improve the design and flexibility of our family beds. While we strive to provide the best service possible, we cannot offer an unlimited guarantee for replacement parts once a bed has been purchased from us.